

DRIVESHAFT ORDER FORM

OFFICE USE
SN:
INV:

BILLING ADDRESS	SHIPPING ADDRESS
-----------------	------------------

NAME:	NAME:
ADDRESS:	ADDRESS:
SUBURB:	SUBURB:
STATE:	STATE:
POSTCODE:	POSTCODE:
PHONE:	PHONE:
FAX:	
E-MAIL:	

DRIVESHAFT DETAILS

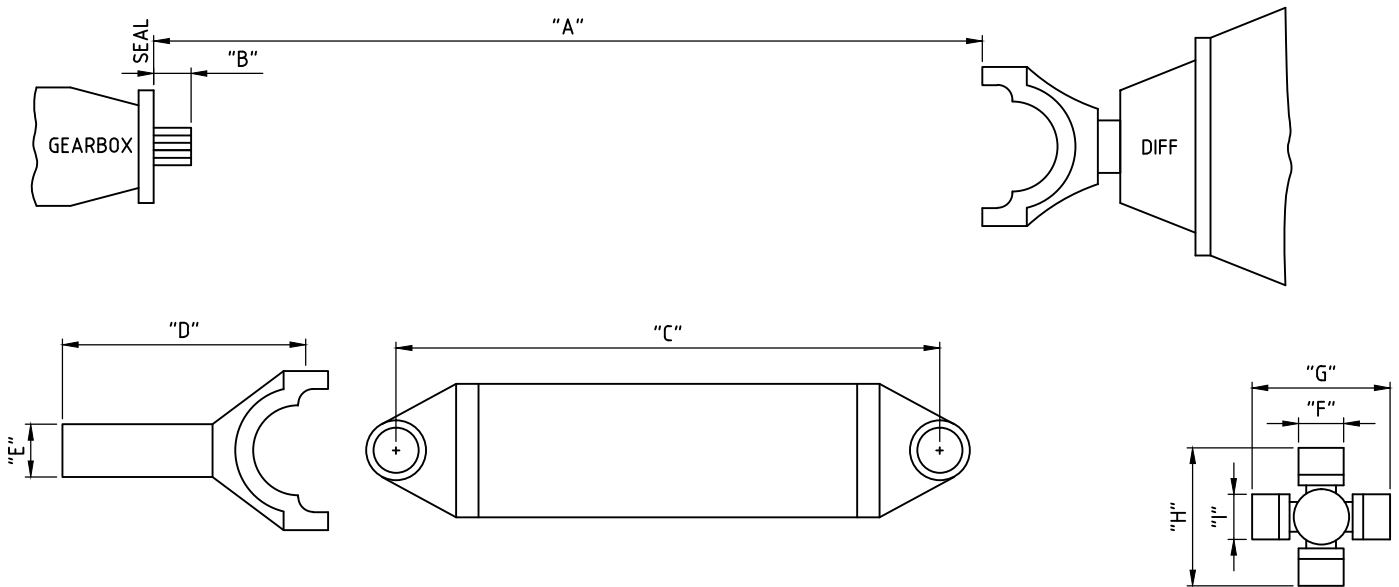

CAR MAKE	:			
CAR MODEL	:	A	:
			B	:
GEARBOX TYPE	:	C	:
			D	:
REAR END TYPE	:	E	:
			F	:
ENGINE HP	:	G	:
			H	:
MAX. R.P.M	:	I	:
GEARBOX SPLINE COUNT	:			

ADDITIONAL INFORMATION:

.....

CONTACT DETAILS

ALTRA 9
 UNIT 2-143 GRANITE STREET
 GEEBUNG
 QLD, 4034

PHONE: (07) 3265 5200
 FAX: (07) 3265 5155

WEB: www.altra9.com.au
 EMAIL: info@altra9.com.au

- WHEN PLACING AN ORDER YOU AGREE TO OUR TERMS AND CONDITIONS
- TERMS AND CONDITIONS ARE AVAILABLE ON WEBSITE
- FULL PAYMENT IS REQUIRED BEFORE ORDER WILL BE PROCESSED

PAYMENT METHODS

EFTPOS, CREDIT CARD(SURCHARGE), CASH,
 DIRECT DEPOSIT : ANZ, ALTRA 9 PTY LTD, BSB: 014 275 , ACCOUNT: 283 947 658