

OFFICE USE
SN:
INV:

NEW PARTS ONLY USED

BILLING ADDRESS	SHIPPING ADDRESS
NAME: .....	NAME: .....
ADDRESS: .....	ADDRESS: .....
SUBURB: .....	SUBURB: .....
STATE: .....	STATE: .....
POSTCODE:.....	POSTCODE:.....
PHONE: .....	PHONE: .....
FAX: .....	
E-MAIL: .....	

**ORDERING INFORMATION**

UNIVERSAL JOINT DIMENSIONS		
TYPE	DIMENSION "	DIMENSION mm
1310	1.062" x 3.225"	Ø26.97mm x 81.91mm
1330	1.062" x 3.625"	Ø26.97mm x 92.07mm
3R	1.125" x 3.625"	Ø28.57mm x 92.07mm
1350	1.185" x 3.625"	Ø30.01mm x 92.07mm

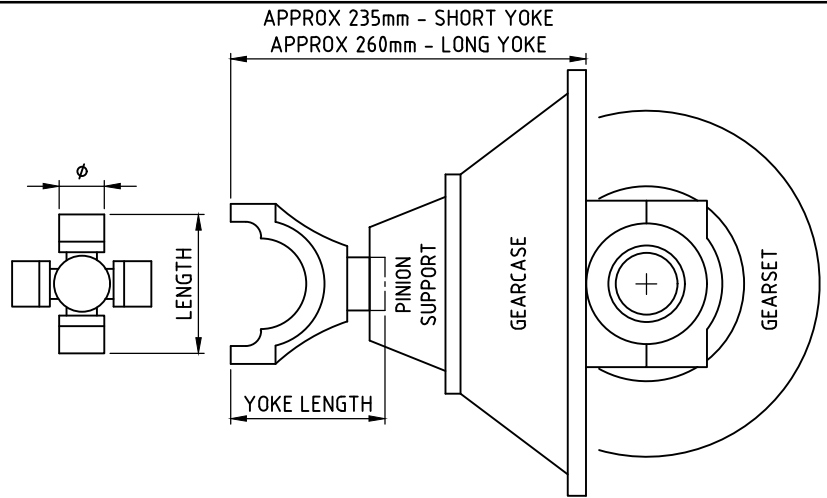

- GEARCASE TYPE : NODULAR IRON SPORTSMAN / NODULAR IRON RACE / ALUM / THRU BOLT ALUM
- PINION SUPPORT TYPE : STANDARD / BIG BEARING
- PINION SUPPORT MATERIAL : NODULAR IRON / ALUM
- YOKE SIZE : 1310 / 1330 / 3R / 1350
- YOKE MATERIAL : NODULAR IRON / MOLLY /ALUM
- YOKE LENGTH : SHORT 102mm / LONG 127mm
- GEARSET RATIO : 2.75 / 3.00 / 3.25 / 3.50 / 3.70 / 3.89 / 4.11 / 4.33 /4.56 /4.88
- GEARSET PINION SIZE : SMALL 28 SPLINE / LARGE 35 SPLINE (Drag racing only)
- GEARSET TYPE : MOTIVE HP / MOTIVE PROGEARS (Drag racing only)
- CARRIER TYPE : TRUETRAC / DETROIT LOCKER / WAVETRAC / FULL SPOOL
- SPLINE : 28 / 31 / 33 / 35 / 40

ADDITIONAL INFORMATION:

.....

**CONTACT DETAILS**

ALTRA 9  
 UNIT 2-143 GRANITE STREET  
 GEEBUNG  
 QLD, 4034

PHONE: (07) 3265 5200  
 FAX: (07) 3265 5155

WEB: [www.altra9.com.au](http://www.altra9.com.au)  
 EMAIL: [info@altra9.com.au](mailto:info@altra9.com.au)

- WHEN PLACING AN ORDER YOU AGREE TO OUR TERMS AND CONDITIONS
- TERMS AND CONDITIONS ARE AVAILABLE ON WEBSITE
- FULL PAYMENT IS REQUIRED BEFORE ORDER WILL BE PROCESSED

PAYMENT METHODS

EFTPOS, CREDIT CARD(SURCHARGE), CASH, DIRECT DEPOSIT